



Fastener
Solutions

Plastic Staple Marketing Specifications

For the following part numbers:

15001-0
15002-0
15003-0
15004-0
15005-0

15016-0

15017-0

April 14, 2020

AVERY DENNISON MARKETING SPECIFICATION

© 2019 AVERY DENNISON CORPORATION. ALL RIGHTS RESERVED

HISTORY

REV.	DATE	DESCRIPTION
D	1-22-20	Released

TENSILE STRENGTH:	2.2 LBF. MINIMUM
WEIGHT:	.25 grams
PACKAGE:	25,000 PER REEL
APPLICATION MACHINE	Avery Dennison ST9500® Attacher See Table for correct model

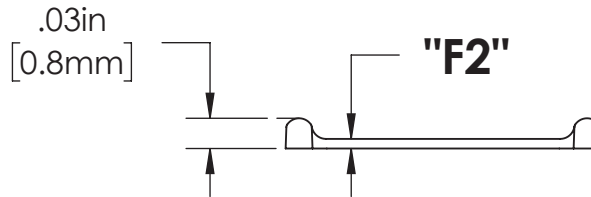
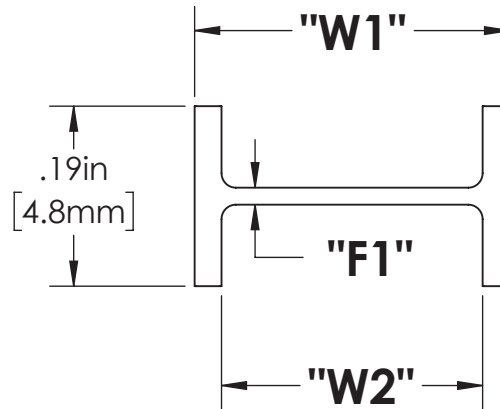

NOT TO SCALE

STOCK NO.	DESCRIPTION	COLOR	APPLICATION MACHINES	DIM "W1"	DIM "W2"	DIM "F1"	DIM "F2"
15001-0	ST9500® Plastic Staple®, 15mm	Clear	15001-1, 15001-2 15001-3	.60 [15.2mm]	.50 [13mm]	.01/.02 [.25mm/.50mm]	.01/.02 [.25mm/.50mm]
15002-0	ST9500® Plastic Staple®, 15mm	White	15001-1, 15001-2 15001-3	.60 [15.2mm]	.50 [13mm]	.01/.02 [.25mm/.50mm]	.01/.02 [.25mm/.50mm]
15003-0	ST9500® Plastic Staple®, 15mm	Black	15001-1, 15001-2 15001-3	.60 [15.2mm]	.50 [13mm]	.01/.02 [.25mm/.50mm]	.01/.02 [.25mm/.50mm]
15004-0	ST9500® Plastic Staple®, 15mm	Grey	15001-1, 15001-2 15001-3	.60 [15.2mm]	.50 [13mm]	.01/.02 [.25mm/.50mm]	.01/.02 [.25mm/.50mm]
15005-0	ST9500® Plastic Staple®, 15mm	Orange	15001-1, 15001-2 15001-3	.60 [15.2mm]	.50 [13mm]	.01/.02 [.25mm/.50mm]	.01/.02 [.25mm/.50mm]
15016-0	ST9500® Plastic Staple®, 8.5mm	Clear	15001-2, 15001-3	.34 [8.5mm]	.24 [6.1mm]	.03/.02 [.75/.50mm]	.01/.02 [.25mm/.50mm]

APPROVALS: ENG. APPR. *W. J. Cooper 1-22-20*
Q.A. APPR. *Rick Estano 2-4-20*



FASTENER DIVISION
FITCHBURG, MA 01420 U.S.A.
TEL. 1-800-225-5913
FAX. 978-353-8157

SPECIFIED TOLERANCES ARE:

.XX ± .03 INCHES .X ± .7 mm
.XXX ± .010 INCHES .XX ± .25 mm
ANGULAR: ± 2°

MATERIAL
Polyurethane
COLOR
See Table

DESCRIPTION Plastic Staple®
ST9500® Fastener
STOCK NO. See Table
REV. **D**

AVERY DENNISON MARKETING SPECIFICATION

© 2019 AVERY DENNISON CORPORATION. ALL RIGHTS RESERVED

HISTORY

REV.	DATE	DESCRIPTION
A	1-22-20	Released

TENSILE STRENGTH:	3.0 LBF. MINIMUM
WEIGHT:	.25 grams
PACKAGE:	25,000 PER REEL
APPLICATION MACHINE	Avery Dennison ST9500® Attacher See Table for correct model

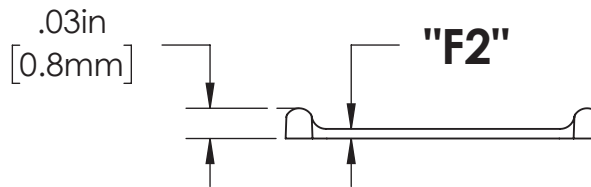
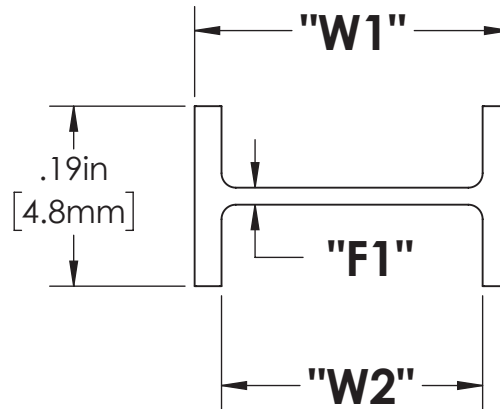

NOT TO SCALE

STOCK NO.	DESCRIPTION	COLOR	APPLICATION MACHINES	DIM "W1"	DIM "W2"	DIM "F1"	DIM "F2"
15017-0	ST9500® Plastic Staple®, 15mm, HD	Clear	15001-2 ,15001-3	.60 [15.2mm]	.50 [13mm]	.04/.03 [1.0mm/.75mm]	.01/.02 [.25mm/.50mm]

APPROVALS:

ENG. APPR. *W. J. Cooper* 1-22-20
Q.A. APPR. *Rick Estano* 2-4-20



FASTENER DIVISION
FITCHBURG, MA 01420 U.S.A.
TEL. 1-800-225-5913
FAX. 978-353-8157

SPECIFIED TOLERANCES ARE:

.XX ± .03 INCHES .X ± .7 mm
.XXX ± .010 INCHES .XX ± .25 mm
ANGULAR: ± 2°

MATERIAL
Polyurethane
COLOR
See Table

DESCRIPTION Plastic Staple®
ST9500® Fastener, Heavy Duty

STOCK NO. See Table

REV.
A